

General Description

The MP1011A is a Power IC offering a complete solution for driving one or more Cold Cathode Fluorescent Lamps (CCFL). This Power IC converts unregulated DC voltage to a nearly pure sine wave required to ignite and operate the CCFL. Based on proprietary power topology and patented control techniques, it greatly increases the power conversion efficiency. The MP1011A supports both **analog** and **burst mode** dimming without any additional external components. The MP1011A offers four distinct performance advantages:

1. **More light for less power**
2. **Small board implementation**
3. **Low EMI emission**
4. **Low cost off the shelf components**

Ordering Information

Part Number *	Package	Temperature
MP1011EMA	TSSOP 20 pin	-20°C to + 85°C

* For Tape & Reel use suffix - Z (e.g. MP1011EMA-Z)

Features

- Integrated power switches
- 6.0 to 22v variable supply voltage with regulated lamp current.
- Rated 12W power output at 12V input
- Open lamp regulation
- Current and Voltage feedback control
- Logic Level burst mode control
- Thermal Shutdown
- Supports Open/Short Lamp protection
- Soft Start
- Output is short circuit protected
- Low lamp operating voltage for increasing transformer or using smaller transformer
- Allows Burst-Mode Operation
- No ballast capacitor required

Applications

LCD backlight inverter for large portable or desktop display.

Typical Application Circuit:

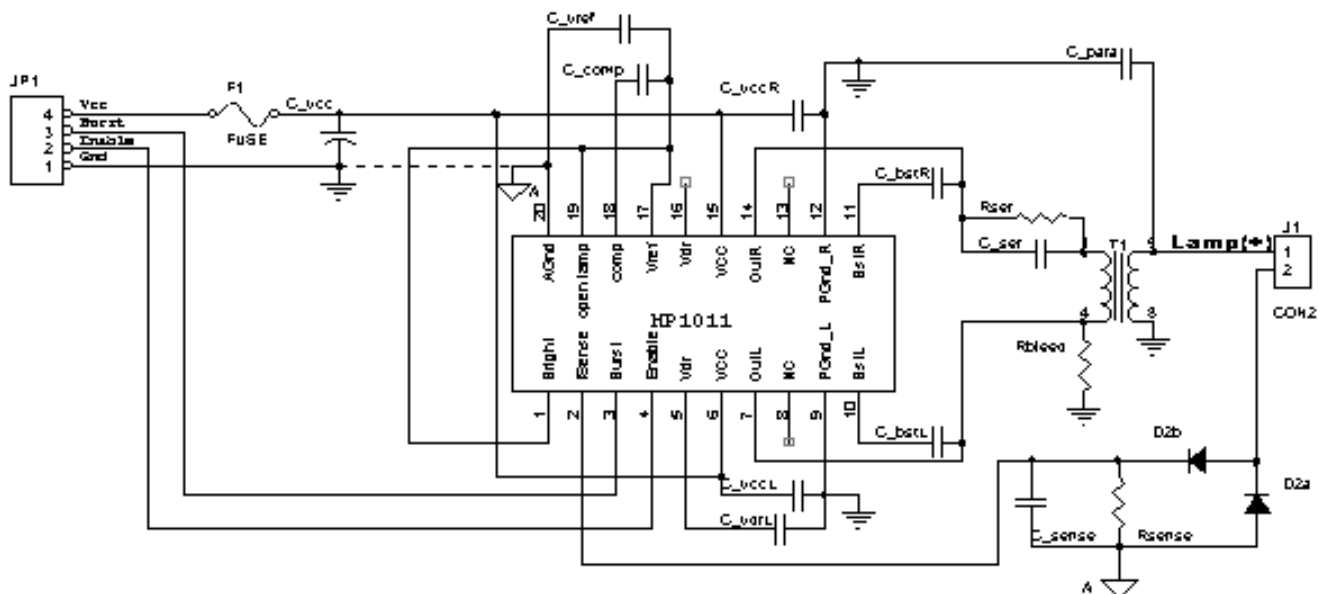

Absolute Maximum Ratings:

Vcc	25 V
Power Dissipation	1.0 W
Logic Inputs	-0.7 V to 6.8V
Thermal resistance	140° C/W
Junction Temperature	150° C
Lead Temperature (Solder)	260° C
Operating Frequency	150KHz
Storage Temperature	-55° C to 150° C

Recommended Operating Conditions:

Input Voltage Vcc	6.0V to 22V
Brightness Voltage	0 to 2.0V
Enable	0 to 5.0 V
Operating Frequency	20KHz to 90KHz
Operating Temperature	-20° C to + 85° C

Electrical Characteristics (Unless otherwise specified Vcc=12v, Ta=25° C)

Parameters	Symbol	Condition	Min	Typ	Max	Units
------------	--------	-----------	-----	-----	-----	-------

Reference Voltage

Output Voltage	Vref	Iref=3mA	4.85	5.1	5.35	V
Reference Current	Iref				3.0	mA
Line Regulation		6.5V < VCC < 22 V			30	mV
Load Regulation		0 < Ire < 3.0 mA			30	mV

Voltage Supply

Supply Current (quiescent)	Icc (off)				10	µA
Supply Current (operating)	Icc (on)	6.0V < Vcc < 22V		1.8	2.5	mA
Operating Range	Vcc	(Note 2)	6.0		22	V

Shutdown Logic

Thermal Shutdown				145		°C
Open Lamp Detect	Vol		1.0	1.2	1.4	V
Enable Voltage Low	Vil				0.6	V
Enable Voltage High	Vih		2.0			V
Burst Voltage Low	Vil				0.8	V
Burst Voltage High	Vih		2.4			V

Output Drivers

On Resistance	Ron	(Note 1)	0.10	0.12	0.15	Ω
Short Circuit Current	Isc			4		A
Operating Frequency			20	60	90	KHz
Zero-Crossing Voltage	Vzc		0	6	10	mV
Ton(min)		Vcomp=0V, Vcc = 22V	500	625	750	nS
Ton(min)		Vcomp=0V, Vcc = 6V	900	1200	1500	nS

Brightness Control

Sense Full Brightness	Vsense	Vbright= 2.0V	357	375	393	mV
Sense Full Dim	Vsense	Vbright= 0V	83	92	101	mV
Lamp Current Regulation		6.0v < Vcc < 22v		2	5	%

Note 1: This parameter is guaranteed by design.

Note 2: See Leakage Inductance Guide lines for Minimum Operating Voltage (Table 2).

Pin Description

Pin #	Pin Name	Pin Function
1	Bright	Dimming Control: 0 volts is full Dim and 2V is full brightness
2	I sense	Lamp current feedback sense input.
3	Burst	To use for burst mode, the pin is switched between 0V and 5V When not using burst mode, then pin must be tied to ground.
4	Enable	The enable will turn the chip on/off. Do not float this pin.
5	Vdr	Internally generated MOSFET gate drive supply voltage
6	Vcc	Power Supply input
7	OutL	Output to Load (tank circuit)
8	NC	No Connect
9	PGND	Power Ground
10	BstL	Regulated output voltage for boost cap on phase L
11	BstR	Regulated output voltage for boost cap on phase R
12	PGND	Power Ground
13	NC	No Connect
14	OutR	Output to Load (tank circuit)
15	Vcc	Power Supply input
16	Vdr	Internally connected to Vdr (pin 5). This pin must be left open.
17	Vref	Reference voltage output
18	Comp	Loop compensation cap
19	Open lamp	Latching shutdown for open lamp or low battery
20	AGND	Small signal ground

Functional Block Diagram:

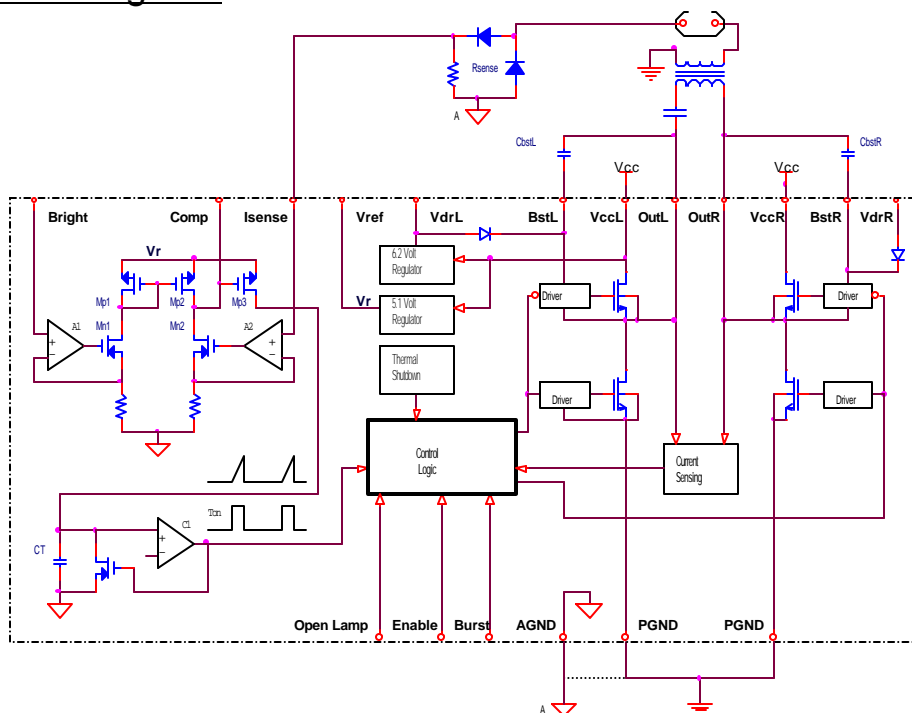

Truth Table

Enable	Burst	Output L /Output R
L	X	High Z
H	H	0 volts (Standby)
L	X	High Z
H	L	Normal Operation

Reference Design for Burst Mode Operation with Open Lamp Regulation and Shutdown

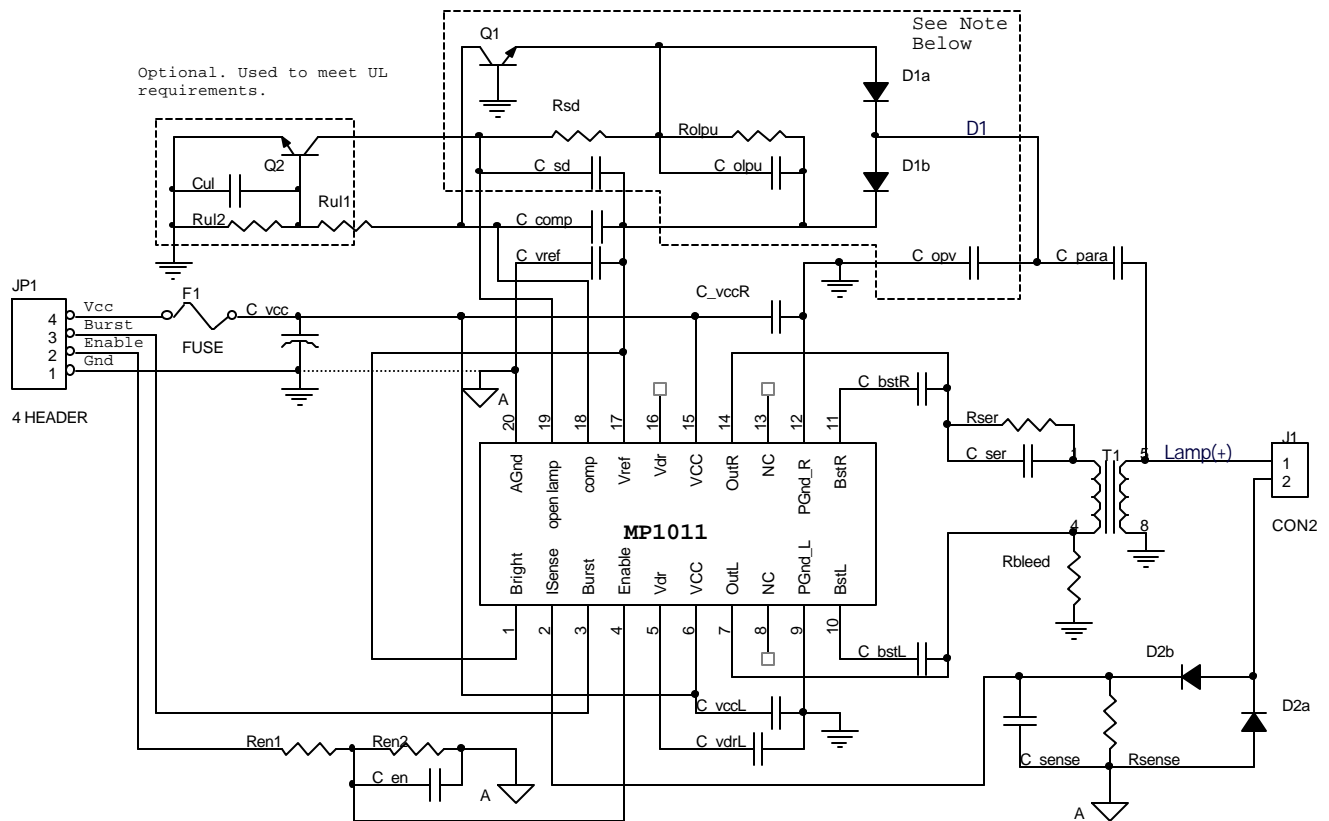

Note: This circuitry is for 'lamp-out' detection. If this feature is not needed, remove the outlined components, short the upper side of C para to Gnd and short pins 17 and 19 of the MP1011.

For additional reference designs, please see MP1011UG demo board user's guide

Table 1 Bill of Materials

Item	Qty	Description	Vendor / Part #	Designation
Resistors				
1	1	4.3K Ω , \pm 5%, SMD, 0805		Rbleed
2	1	100K Ω , \pm 5%, SMD, 0805		Ren1
3	1	100K Ω , \pm 5%, SMD, 0805		Ren2
4	2	1M Ω , \pm 5%, SMD, 0805		Rsd, Rolpu
5	1	140 Ω , \pm 1%, SMD, 0805		Rsense
6	1	1K Ω , \pm 5%, SMD, 0805		Rser
7	1	2M Ω , \pm 5%, SMD, 0805	(For UL)	Rul1
8	1	280K Ω , \pm 5%, SMD, 0805	(For UL)	Rul2
Capacitors				
9	2	10nF, 50V, Y5V, SMD		C_bstL, C_bstR
10	2	10nF, 16V, X7R, SMD		C_olpu, C_comp
11	1	100pF 50V NPO		C_en
12	1	1uF 6.3V X7R		C_sd
13	1	6.8nF 16V X7R		C_opv
14	1	10pF, 3KV		C_para
15	1	0.22uF, 16V, Y5V, (optional)		C_sense
16	1	2X.47uF 16V X7R		C_ser
17	2	1uF 25V Y5V		C_vccR, C_vccL
18	1	10uF, 25V, Y5U, SMD, 1210		C_vcc
19	1	220nF, 10V Y5V, SMD		C_vdrL
20	1	0.1uF, 10V, X7R, SMD		C_vref
21	1	100nF, 10V, Y5Y, SMD	(for UL)	Cul
Semiconductors				
22	4	Diode, BAV99L		D1b, D1a, D2b, D2a
23	2	Transistor, bipolar, 2N3904, SMD		Q1, Q2
Integrated Circuits				
24	1	MP1011A, 20-pin TSSOP	Monolithic Power Systems	U2
Magnetics				
25	1	Transformer*		T1
Hardware				
26	1	Fuse, 1A		F1

***Transformer Sources:**

<u>Company</u>	<u>Part #</u>	<u>Location</u>	<u>Contact Info</u>
Toko	BLC103B	Saitama-Ken, Japan	http://www.toko.co.jp +81-492-791611
Darfon Electronics Corp.	Contact Vendor	Taoyuan 333, Taiwan	+886-3-329-4141
FDK	CD-T-0836-520	Yamaguchi, Japan	http://www.fdk.co.jp
TMP	Contact Vendor	Taipei, Taiwan	+886-2-8667-2081

Table 2: Leakage Inductance Guide Lines for Minimum Operating Voltage

Minimum Operating Supply Voltage	Recommended Maximum Primary Leakage Inductance*
6	38 μ H
7	42 μ H
8	45 μ H
9	47 μ H
10	49 μ H

* If the maximum primary leakage cannot be met, consult factory for alternatives.

Packaging Information

